

GT SERIES

Wet Prime Centrifugal Pump

GT3087

The Pioneer Pump® GT Series is a robust pumping solution for nearly any food processing, wastewater treatment, waste handling, chemical processing, or industrial application with high performance demands. Now available in 3x3 and 4x4 sizes in addition to the 6x6 sizes, this product family features a robust shaft design that permits maximum flow rates up to 2250 gpm at a maximum head of 250 feet with a solids handling capability of up to three inches. The case inlet diameter is uniquely designed to alleviate abrasive wear on the pump and a unique cover design combines both the fill and flapper valve access cover into one part to improve ease of use – making these pumps ideal for the toughest tasks, all within a standard footprint.



PERFORMANCE

Size	3" x 3" (80 x 80 mm)
Max Flow	660 gpm (150 m ³ /h)
Max Head	160 feet (49 meters)
Max Speed	2,600 rpm
Max Efficiency	45%
Flow at BEP	470 gpm (106 m ³ /h)
Max Solids Handling	2.5" (63 mm)
Bearing Lubrication	Standard Oil
Fasteners	English

APPLICATIONS

Industrial	Oil Field
Municipal	Agriculture
Construction	Food Processing
Wastewater	Mining
Petrochemical	

DRIVE OPTIONS

Bareshaft Pump End	Electric Driven Trailer
Overhead Belt Drive	Diesel Driven Trailer
Electric Direct Drive w/ Guard	SAE engine-mount bracket options available

FEATURES

- Rugged ductile-iron casing and impellers for added strength and dependability
- Highly reliable and corrosion-resistant 17-4 stainless steel shaft
- Double-lip seal with atmospheric drain for additional bearing protection within the rotating assembly
- Cartridge-type SC/TC (silicon carbide/tungsten carbide) mechanical seal for simple installation and ease of maintenance

MATERIALS OF CONSTRUCTION

	Standard Materials
Impeller	ASTM A536 Ductile Iron 65-45-12
Volute	ASTM A536 Ductile Iron 65-45-12
Inspection Cover	ASTM A48 Class 30 Gray Iron
Wear Plate	1018 Steel
Seal Plate	ASTM A48 Class 30 Gray Iron
Bearing Housing	ASTM A48 Class 30 Gray Iron

MECHANICAL DIMENSIONS

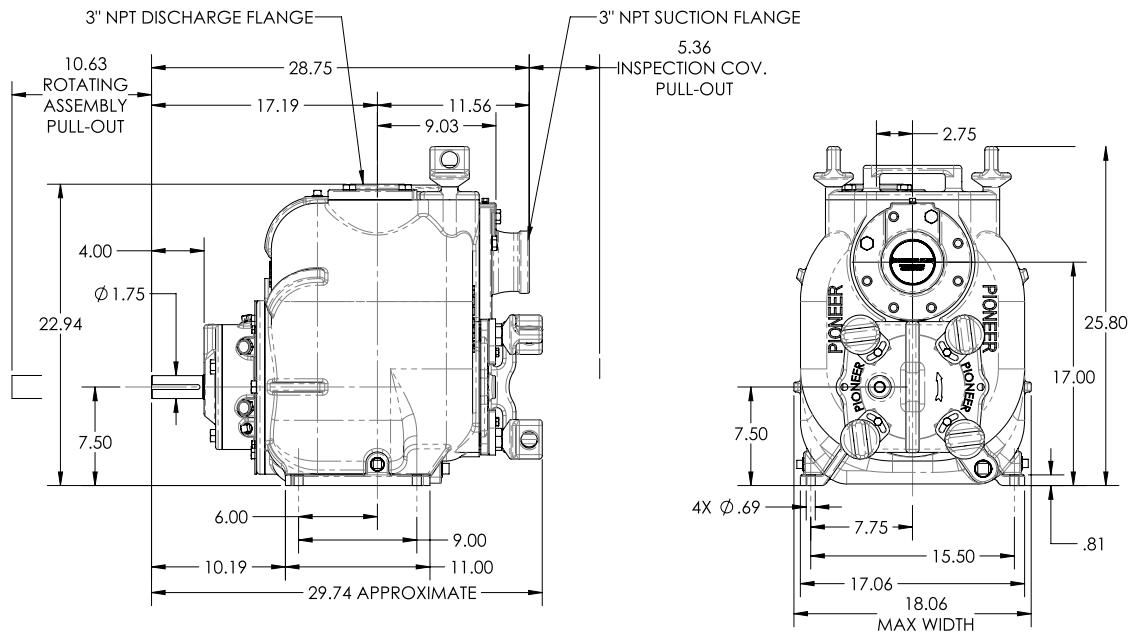

PERFORMANCE CURVE

Model: GT3087

Impeller Dia: 8.75"

Speed: Variable

Solids Size: 2.5"

Curve #GT3087-VS

