

GREENLINE

Pioneer Prime Diesel-Driven Centrifugal Pump

PP44S10L71-D2.9L-GL2



PUMP SPECIFICATIONS

Size	4" x 4" (100 x 100 mm)
Max Flow	1,600 gpm (370 m ³ /h)
Max Head	150 feet (50 meters)
Solids Size	3" (76 mm)

ENGINE SPECIFICATIONS

Engine Type	Deutz D2.9L, 4-Cylinder Diesel, Final Tier 4
Displacement	177 cu. in. (2.9 l)
Fuel Burn Rate (gph)	1.95 gph (full load)
Continuous HP	36 HP @ 1800 rpm
Safety Shut Down Switches	Low oil pressure, high temperature, and v-belt failure
Instrument Panel	Oil pressure gauge, ampmeter, hourmeter, and tachometer

ULTRAPRIME™ PRIMING SYSTEM

Priming System	Mech. driven diaphragm-style vacuum pump
Air Removal Capability	50 cfm
Priming Chamber	Positive sealing air separation PosiValve™ w/SS float ball & linkage
Discharge Check Valve	Swing style; ductile iron w/nitrile disc
Run Dry System	Oil-lubricated mech. seal allows pump to run completely dry w/o damage

FEATURES

- Indefinite run-dry capability
- Extreme flow technology
- Environmentally safe priming system with patented PosiValve™
- Auto-start controls
- Electric trailer brakes optional

SPECIFICATIONS

Fuel Capacity	75 gallons
Control Panel	Murphy MPC-10
Dimensions (L x W x H)	131 x 70 x 73
Runtime (hours)	38.5 hours
Other Specifications	Vibration isolated, lifting bail, leak-proof diesel cap, analog fuel gauge, tank clean-out, drip pan drain
SAE	SAE engine-mount bracket options available

MATERIALS OF CONSTRUCTION

Material	Standard Construction
Impeller	CA6NM SS
Shaft	17-4 PH
Wear Ring	Gray Iron
Suction Cover	Ductile Iron
Volute	Ductile Iron
Brac-Plate/Bracket	Ductile Iron
Mechanical Seal	Tungsten vs. Silicon Carbide

MECHANICAL DIMENSIONS

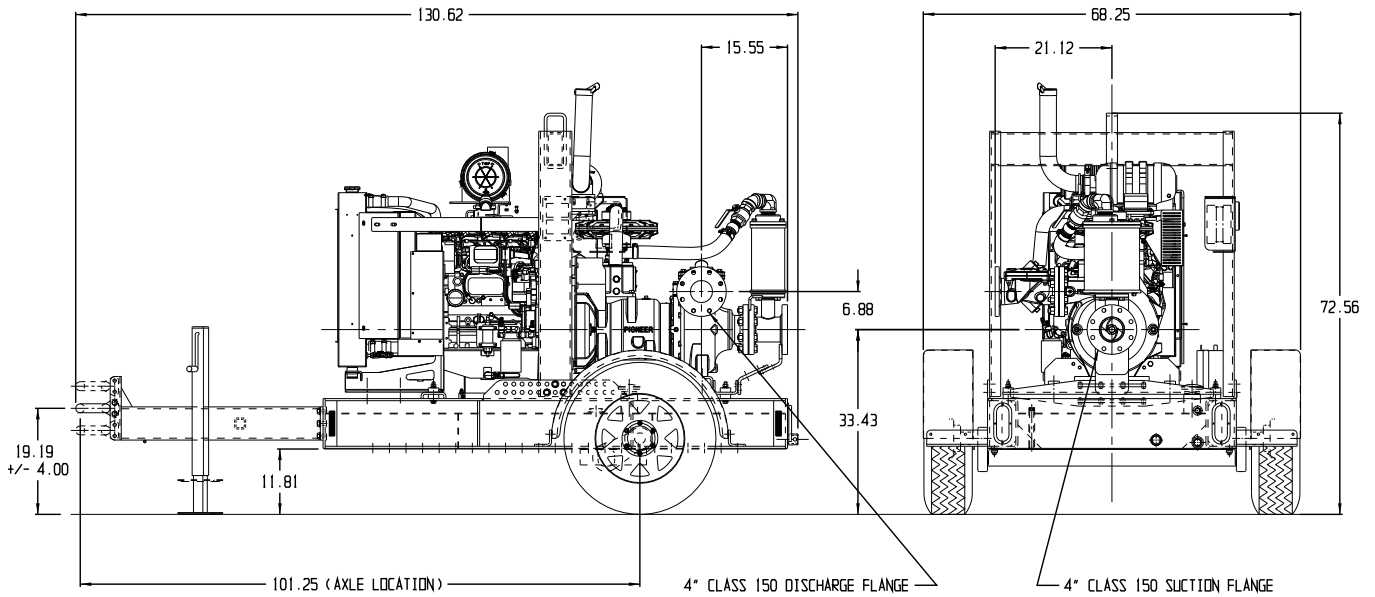

PERFORMANCE CURVE

Model: PP44S10

Impeller Dia: 10"

Solids Size: 3"

Curve #07903HQ

