

Standard Centrifugal

SC86C17L71



PERFORMANCE

End Suction Standard Centrifugal Pump

Bare shaft, frame mounted, heavy duty pump

Size	8" x 6" 200 x 150 mm
Flow, Max	4,200 USgpm 970 m ³ /h 270 l/s
Head, Max	490 feet 150 meters
Flow at BEP	3,900 USgpm 890 m ³ /h 250 l/s
Efficiency at BEP	84%
Solids Handling, Max	1.5" 38 mm
Operating Speed, Max	2200 rpm
Suction Connection	8" (200 mm) 150 ANSI Flanges
Delivery Connection	6" (150 mm) 150 ANSI Flanges
Bearing Lubrication	Oil STD Grease optional
Fasteners	Imperial

High Pressure, High Flow, Heavy Duty Pump

Designed to operate over a broad range of performance while delivering outstanding suction lift, the SC86C17 is the clear choice. The rugged construction and modular design provide proven reliability and flexibility in the most demanding applications.

SPECIFICATIONS

Mechanical Seal	Single Type Seal w/ Tungsten Carbide vs. Silicon Carbide Seal Faces, Viton Elastomers, 300 Series Stainless Steel Hardware and Spring (Run Dry Option Available)
Pump End Bearing	Single Row Ball
Drive End Bearing	Double Row Angular Contact
Shaft	17-4 PH Stainless Steel
SAE	SAE engine-mount bracket options available

CONSTRUCTION MATERIALS

Material	Standard Construction	CD4MCu Stainless Steel
Impeller	CA6NM SS	CD4MCu
Volute	Ductile Iron ASTM A536 65-45-12	CD4MCu
Wear Ring	ASTM A48 Class 40 Gray Iron	316 SS
Suction Cover	Ductile Iron ASTM A536 65-45-12	CD4MCu
Brac-plate	Ductile Iron ASTM A536 65-45-12	CD4MCu

APPLICATIONS

Quarry	Firefighting
Dust Suppression	Steel
Mining	Oil & Gas

MECHANICAL DIMENSIONS

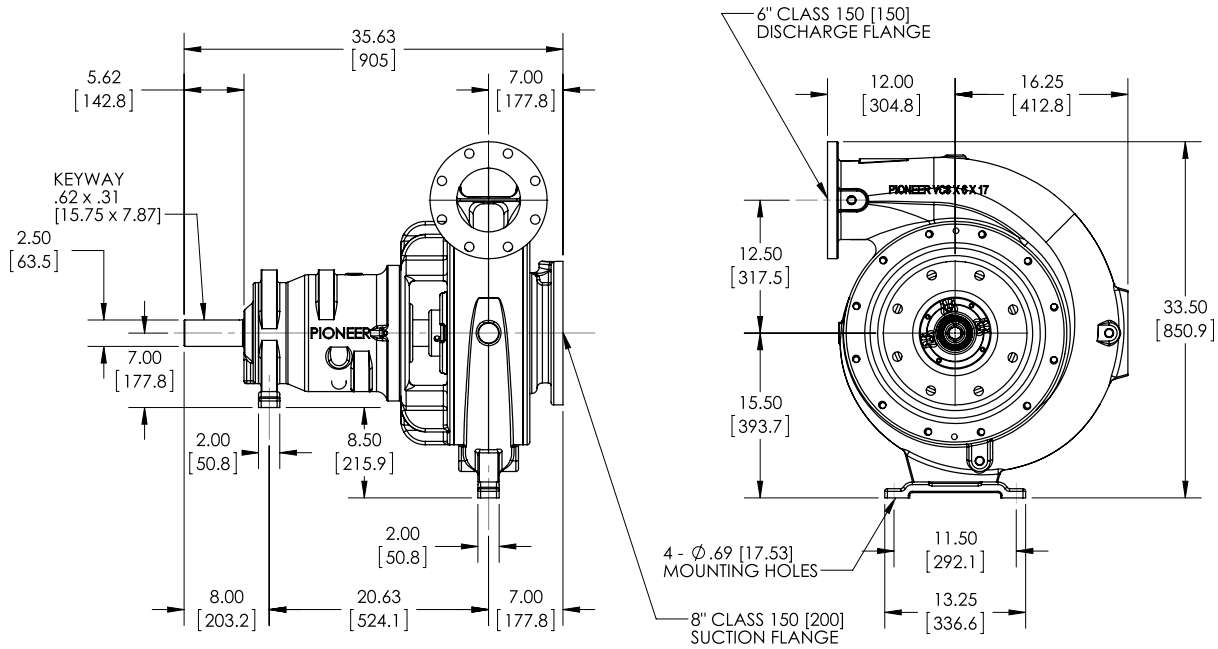

PERFORMANCE CURVE

Model: SC86C17

Impeller Dia.: 17"

Speed: Variable

Solids Size: 1.5"

Curve #SC86C17-VS-17

