

Standard Centrifugal

SC64S17L71



Typical Pump Configuration

Performance

End suction standard centrifugal pump

Bare shaft, frame mounted, heavy duty, solids handling pump

Size	6" x 4" 150 x 100 mm
Flow, Max	3,125 USgpm 720 m ³ /h 200 l/s
Head, Max	500 feet 150 meters
Flow at BEP	1,750 USgpm 400 m ³ /h 110 l/s
Efficiency at BEP	70%
Solids Handling, Max	3.0" 76 mm
Operating Speed, Max	2100 rpm
Suction Connection	6" (150 mm) 150 ANSI Flanges
Delivery Connection	4" (100 mm) 150 ANSI Flanges
Bearing Lubrication	Oil STD Grease optional
Fasteners	Imperial

Applications

Dirty water	Raw water pumps
Sewage bypass	Flood pumps
Silt returns	Mine dewatering
Cooling pumps	

High pressure, high flow, heavy duty solids handling pump

Designed to run over a broad range of performance while delivering outstanding suction lift, the SC64S17 is the solid choice. The rugged construction and modular design provide proven reliability and flexibility in the most demanding applications.

Optional Priming System

Priming System	Mechanically Driven Diaphragm Style Vacuum Pump
Air Removal Capability	50 CFM
Priming Chamber	Single chamber with positive sealing air separation PosiValve™ with stainless steel float ball & linkage.
Discharge Check Valve	Swing Style - ductile iron with Buna-n Disc

Other Specifications

Mechanical Seal	Single Type Seal w/ Tungsten Carbide vs. Silicon Carbide Seal Faces, Viton Elastomers, 300 Series Stainless Steel Hardware and Spring (Run Dry Option Available).
Pump End Bearing	Single row ball
Drive End Bearing	Double Row Angular Contact
Shaft	17-4 PH Stainless Steel

Construction Materials

	Standard Construction	CD4MCu Stainless Steel
Impeller	CA6NM SS	CD4MCu
Volute	Ductile Iron ASTM A536 65-45-12	CD4MCu
Wear Ring	ASTM A48 Class 40 Gray Iron	316 SS
Suction Cover	Ductile Iron ASTM A536 65-45-12	CD4MCu
Brac-plate	Ductile Iron ASTM A536 65-45-12	CD4MCu

Mechanical Dimensions



Typical Pump Configuration

SC64S17

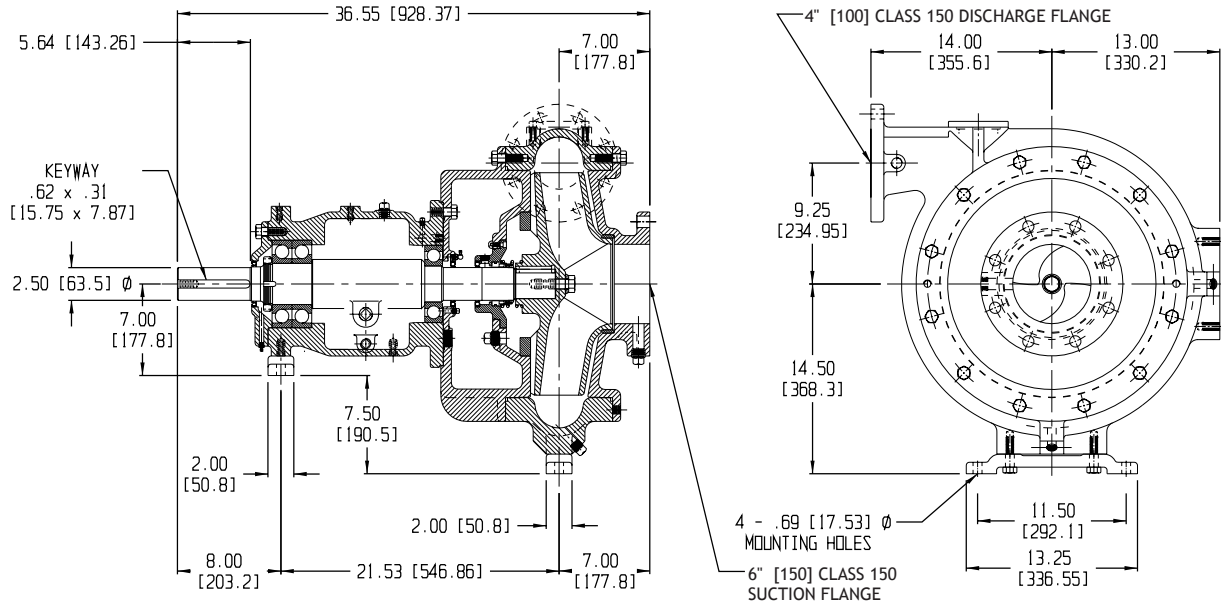

Performance Curve

Model: SC64S17	Impeller Dia: 17"	Speed: Variable	Solids Size: 3.0"	Curve #07630HQ
----------------	-------------------	-----------------	-------------------	----------------

